

Undercounter Warewasher
ValueLine U50

winterhalter

High Performance to the Core



Robust construction and the best cleaning results

The U50 is a robust undercounter warewasher from the Winterhalter ValueLine that delivers the best cleaning results. It is easy to operate provides with efficient operation and is easy to maintain. Additionally, U50 is characterised by reduced noise levels. Users can trust in its level of efficiency, hygiene and reliability. This makes the U50 extremely attractive for professionals in search of an economical and practical solution for their growing warewashing needs.



Easy to operate

- Simple, clear with colour-coded controls made from robust CN-switches
- Integrated temperature displays for tank and boiler
- Self explanatory operation
- Electro mechanical control
- Ergonomic door handle



Excellent results and perfect hygiene

- Rotating top and bottom wash system for optimum coverage
- Wash and rinse arms easily removable by hand for cleaning
- Hygiene rack guide
- Removable rack guides offer better access for cleaning and maintenance



Economical to run

- Full coverage filtration system – less water changes due to cleaner wash water
- Low capacity wash tank for quicker start-up and lower bills
- Double walled door with solid construction reduces noise and heat emission

Technical Data

U50		
Number of programmes		1
Theoretical capacity	[racks/h]	30
Water consumption		
Tank capacity	[l]	18
Rinse water consumption per cycle	[l]	2.7
Temperatures		
Tank temperature	[°C]	62
Rinse temperature	[°C]	85
Electrical specifications		
Total connected load		
– Three-phase AC	[kW]	6.84
– Alternating current	[kW]	6.84
Fuse protection		
– Three-phase AC	[A]	16
– Alternating current	[A]	32
Circulating pump (P1)	[kW]	0.84
Tank heating	[kW]	2
Boiler heating	[kW]	6
Other information		
Max. water inlet temperature	[°C]	60
Required water flow pressure for pressure boiler	[bar]	2
Required water flow pressure for non pressurized boiler	[bar]	1
Splash guard		IP X3
Weight, net/gross	[kg]	66/71

Dimensions

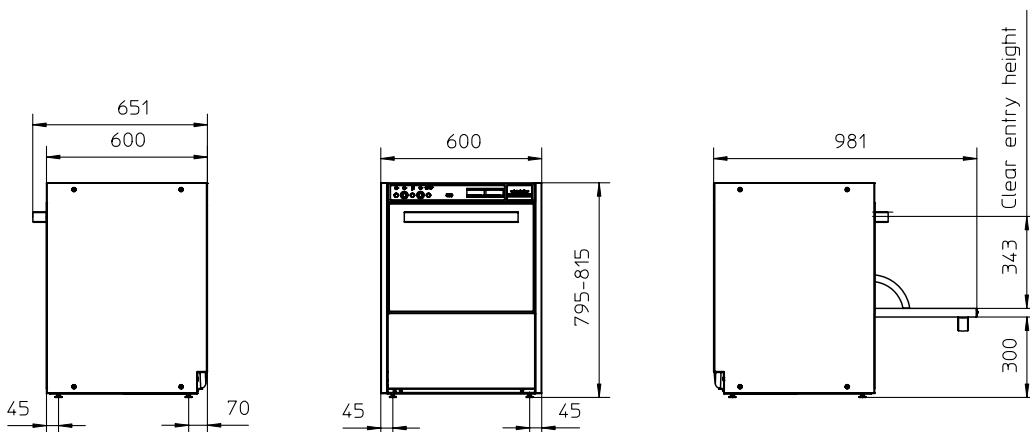

SEA Regional Office:**Winterhalter (M) Sdn. Bhd.**

12, Jalan PJU 3/46,
Sunway Damansara Technology Park,
47810 Petaling Jaya Selangor, Malaysia
Tel.: +6 03 7803 6621; Fax: +6 03 7803 1129
www.winterhalter.com.my

PT. Winterhalter Indonesia PMA

Rukan Inkopal Blok G46-47,
Jl. Boulevard Barat Raya - Kelapa Gading,
Jakarta Utara 14240, Indonesia.
Tel.: +62 21 4585 1556; Fax: +62 21 4585 1554
www.winterhalter.co.id

Winterhalter Singapore Pte Ltd

Blk 186, Woodlands Industrial Park E5
#03-01E Singapore 757515
Tel.: +65 6368 5808; Fax: +65 6368 1880
www.winterhalter.sg

Winterhalter Gastronom Vietnam Co., Ltd.

660 Dien Bien Phu Street,
Ward 11, District 10, HCMC, Vietnam.
Tel.: +848 3830 1795; Fax: +848 3830 1796
www.winterhalter.vn

Winterhalter (Thailand) Co, Ltd.

174 Lad Phrao 64,
Lad Phrao Road, Wong Thong Lang,
Bangkok 10310, Thailand.
Tel.: +66 2 539 3279; Fax: +66 2 539 3280
www.winterhalter.co.th